

MODEL: 5LBS5436E75B*

BARRIER FREE

ALL ACCESSORIES OPTIONAL

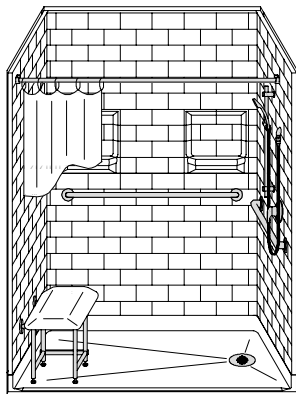

PERSPECTIVE VIEW - N.T.S.

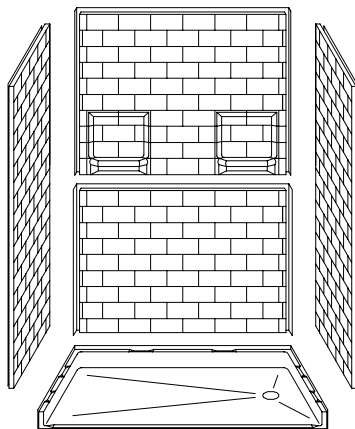

ASSEMBLY VIEW - N.T.S.

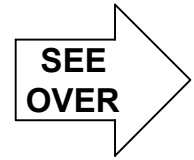
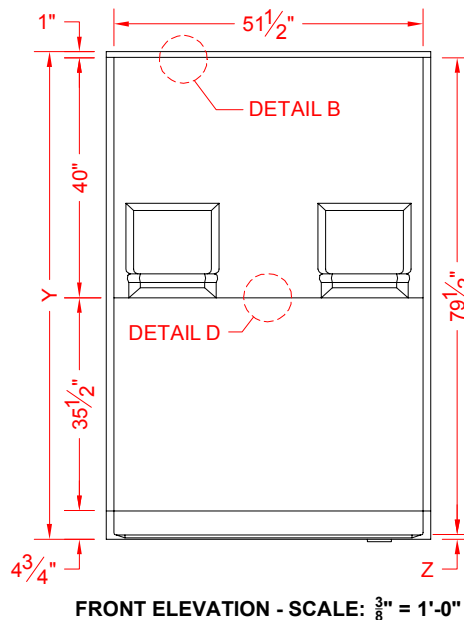
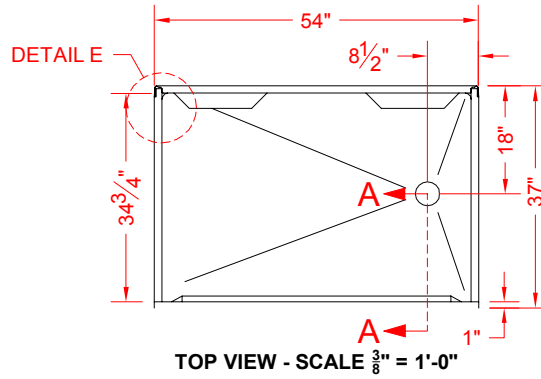

Features:

- Molded, five-piece gelcoat/fiberglass shower module
- "Subway Tile" wall finish, white (standard)
- Integral full wood backing for strength and unlimited accessory placement
- On all threshold heights 1-1/2" or taller, no mud set is required
- On all threshold heights 1-1/4" or shorter, no mud set is required and an anchoring adhesive kit is supplied

MODEL #	UNIT HEIGHT Y	THRESHOLD HEIGHT Z*
5LBS5436E75B	81-1/4"	3/4" MIN.
5LBS5436E2B	82-1/2"	2" MAX.

* - SEE BACK FOR DETAIL SECTIONS

PRODUCT SPECIFICATIONS:

- Multi-piece shower module shall be constructed of gelcoat/fiberglass with full integral plywood backing
- Rough-In: Stud opening +1/4" -0" Nominal Dimensions.

C.S.I. FORMAT SPECIFICATION TEXT AVAILABLE

PRODUCT INFORMATION:

- Accessories: Polished chrome/satin stainless standard, others available.
- Colors: White as standard, others to match any major fixture manufacturer, also available with sprayable solid surface in many colors
- Custom curb heights, other than shown, are available (between min. and max.)

ACCESSORIES:

INSTALLED BY OTHERS:

- Grab bar
- Seat, folding
- Mixing valve, pressure balanced, lever handle, preplumbed tree to supply elbow
- Curtain and rod
- T-Shaped rubber WaterStopper kit
- Semi-permanent threshold adaptor
- No-caulk brass drain

CODES:

- Designed and manufactured in compliance with the following standards and codes:
- A.N.S.I. Z124.2 Standards for Plastic Showers

NOTICE OF LIMITATION:

- Does not meet:
- I.P.C. International Plumbing Code
- U.P.C. Uniform Plumbing Code



www.orcahealthcare.com
Tel: 1-855-566-6722



We reserve the right to make revisions without notice in the design of fixtures or in packaging unless this right has specifically been waived at the time the order is accepted.

5LBS5436E75B

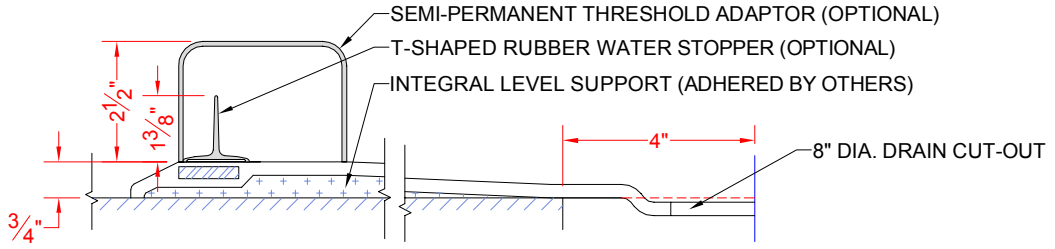

SECTION A-A - SCALE: 3" = 1'-0"

5LBS5436E2B

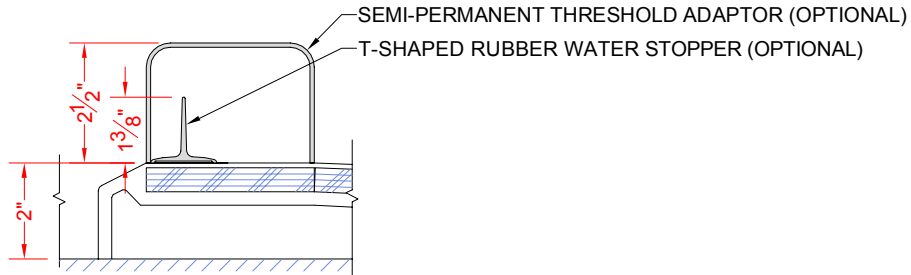

SECTION A-A - SCALE: 3" = 1'-0"

****OTHER THRESHOLD HEIGHTS AVAILABLE UPON REQUEST****

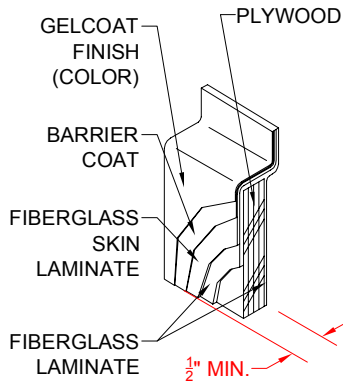

DETAIL B - SCALE: 3" = 1'-0"
 WALL SECTION DETAIL

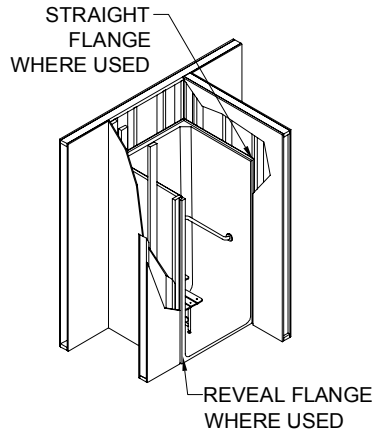

DETAIL C - SCALE: NTS
 TYPICAL FRAMING

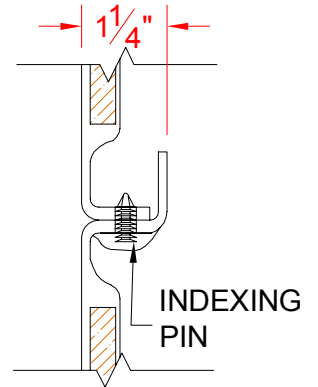

DETAIL D - SCALE: NTS
 BACKWALL JOINT DETAIL

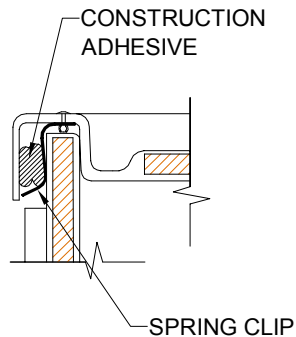

DETAIL E - SCALE: NTS
 WALL JOINT DETAIL

