

MODEL: LTOW5030 Jetted L/R

ESCAPE Jetted

SHOWN WITH OPTIONAL THREE PIECE WALL SURROUND AND DECK EXTENSION

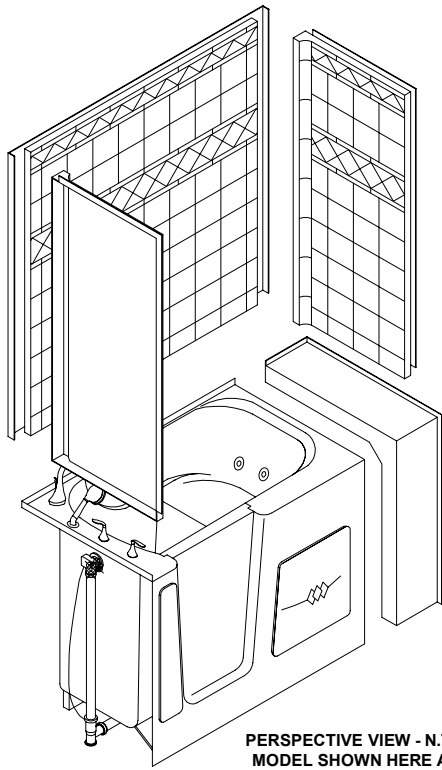

PERSPECTIVE VIEW - N.T.S.
MODEL SHOWN HERE AS:
LEFT HAND

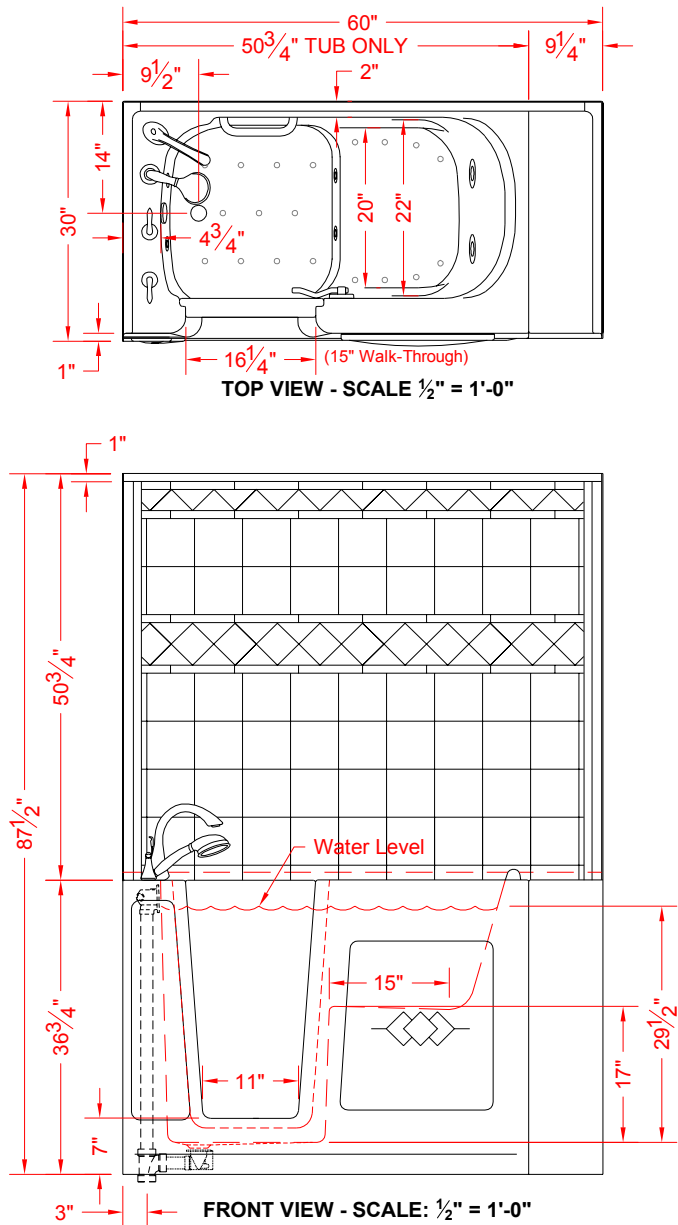

Features:

- Designed to fit in the space of your current bathtub
- Seat height is designed for ease of sitting and standing
- Extra deep for a full body soak
- Innovative new door handle designed for easy operation
- Reliable door seal that comes with a lifetime warranty
- Heated seat for comfort while draining
- Tile Look Wall surround system with integral plywood backing and SnapJoint for quick assembly
- Syllent brand water jet pump: a revolutionary, ultra quiet design that helps maintain water temperature without an external heater, limiting the power requirements to just 15 Amps/110 Volt
- Optional (heated) Air jet system (15 Amps/110 Volt)
- Allows you the freedom to rehabilitate at home
- Space under tub allows for "reverse" plumbing.

PRODUCT SPECIFICATIONS:

- Walk-in jetted bathtub with pressure sealed door shall be of gelcoat / fiberglass construction and have an integral front skirt, magnetically attached access panels for plumbing and deck/skirt extension.
 - The matching wall system shall have integral plywood backing and a SnapJoint assembly feature.
- C.S.I. FORMAT SPECIFICATION TEXT AVAILABLE

PRODUCT INFORMATION:

- Accessories: Factory installed Tub Bar and optional plumbing rough-in, all others installed by others
- Colors: White as standard, Almond optional
- Also available with sprayable solid surface in many colors
- Fill volume with a 170 lbs. bather: 60 gallons
- Tub weight, dry, approx. 209 lbs.
- Total weight of jetted tub, bather, and water: approx. 775 lbs.

Power Requirements:

- Water jet system 120V/15A (draws 9.4A)
- Air jet System 120V/15A (draws 9.5A)
- Heated Seat 120V/15A (draws 0.2A)
- Ozone Generator 120V/15A (draws 0.4A)
- Water Pump - US: Syllent MB71E0032AS/UL
- CAN: Syllent MB71E0032AS/UL-M
- Air Pump - US/CAN: CG Air SLO-3-75-120/60A-N
- Suction Fitting: CG Air SUC-S

ACCESSORIES:

STANDARD:

- Tub bar
- Cable operated tub drain
- Syllent Brand Jet Pump with 6 directional jets and air volume control
- Heated seat

OPTIONAL:

- Roman tub filler
- Hand shower
- Thermostatic mixing valve
- Grab bars for installation on wall surround
- Custom Tile Accenting on Wall
- Air jet system for additional therapy action using preheated air
- Window trim kit
- Flange trim kit
- Ozone sanitation system

CODES:

Designed and manufactured in compliance with the following standards and codes:

- C.S.A. B45.5-11 / A.N.S.I. Z124-201 Plastic Plumbing Fixtures
- A.S.M.E. A112.19.7M-1995 Whirlpool Bathtub Appliances
- A.S.M.E. A112.19.8M-1987 Suction Fittings for use in Whirlpool Bathtubs
- A.S.M.E. A112.19.15-2001 Bathtubs / Whirlpool Bathtubs with pressure sealed doors
- Underwriters Laboratories 1795 Hydro Massage Bathtubs



www.orcahealthcare.com
Tel: 1-855-566-6722



We reserve the right to make revisions without notice in the design of fixtures or in packaging unless this right has specifically been waived at the time the order is accepted.

ESCAPE / ESCAPE PLUS WALK-IN JETTED BATHTUB CONFIGURATIONS AVAILABLE:

①

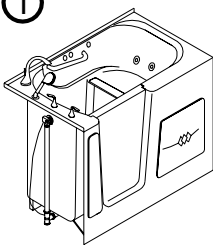

- No additional accessories included.

②

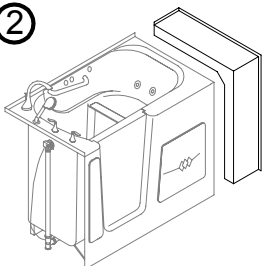

- With Deck Extension
- Fits in the space of a typical 5 ft. bathtub or shower
- Generally for an ALCOVE installation.

Escape Deck Extension
Model # ESC-1000 (RH) / ESC-1001 (LH)

③

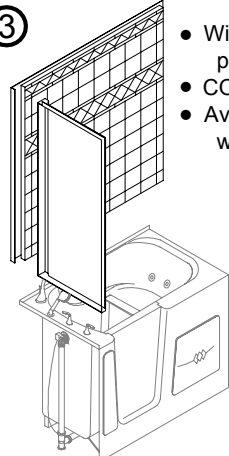

- With two walls: a back wall and a plumbing side wall.
- CORNER installation
- Available for all standard configurations with a Universal wall system.

Universal
Model # 2DWSU6030 L/R

④

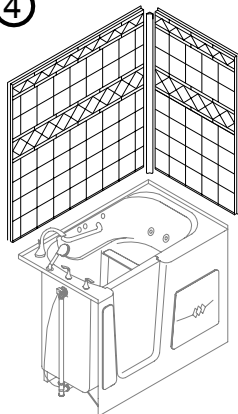

- With two walls: a back wall and an opposite plumbing side wall.
- Reverse CORNER installation
- Available for custom configurations with a Universal wall system.
- This configuration requires an add-on nailing flange.

Universal
Model # 2DWSU6030 L/R

⑤

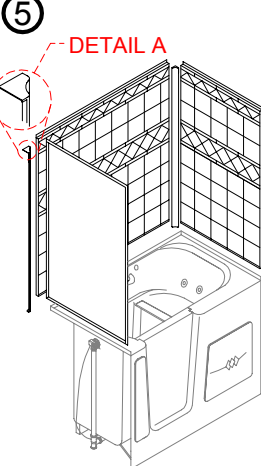

- With three walls: a back wall and two side walls.
- ALCOVE installation for a framing pocket of 50-3/4" x 30"
- Available for custom configurations or new construction in the Universal** wall system only.
- This configuration requires an add-on nailing flange.

** Universal
Model # 3DWSU6030

⑥

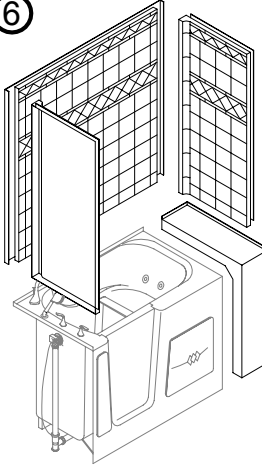

- With Deck Extension and three walls: a back wall and two side walls.
- ALCOVE installation for a framing pocket of 60" x 30"
- Available for all standard configurations in both SnapJoint* and Universal** wall systems.

* SnapJoint
Model # 3WIDWS6030

** Universal
Model # 3DWSU6030

Escape Deck Extension
Model # ESC-1000 (RH) / ESC-1001 (LH)

*SnapJoint Wall System:

- Standard wall system for square framing
- Quick, easy "snap-in" installation

**Universal Wall System (including Corner Trim: DETAIL A in option # 5) can be cut to accommodate:

- Options # 3, 4, and 5
- Any configuration with out-of-square walls or framing
- Other unusual situations



www.orcahealthcare.com
Tel: 1-855-566-6722



We reserve the right to make revisions without notice in the design of fixtures or in packaging unless this right has specifically been waived at the time the order is accepted.